

MHS8203 HORIZONTAL SCREEN MODULE FEATURES

Terex® Cedarapids LJ-TSV
horizontal screen 8' x 20'
(2438 mm x 6096 mm) 3-deck

Entire module transports
easily in 40' (12.2 m)
shipping containers

CE compliant structure
and components

Extra-heavy-duty
I-beam frame

60" (1524 mm) fully skirted
underscreen fines conveyor

Pre-wired "plug and play" design,
minimal on-site wiring

Weather protected user-friendly
IP55 control panel

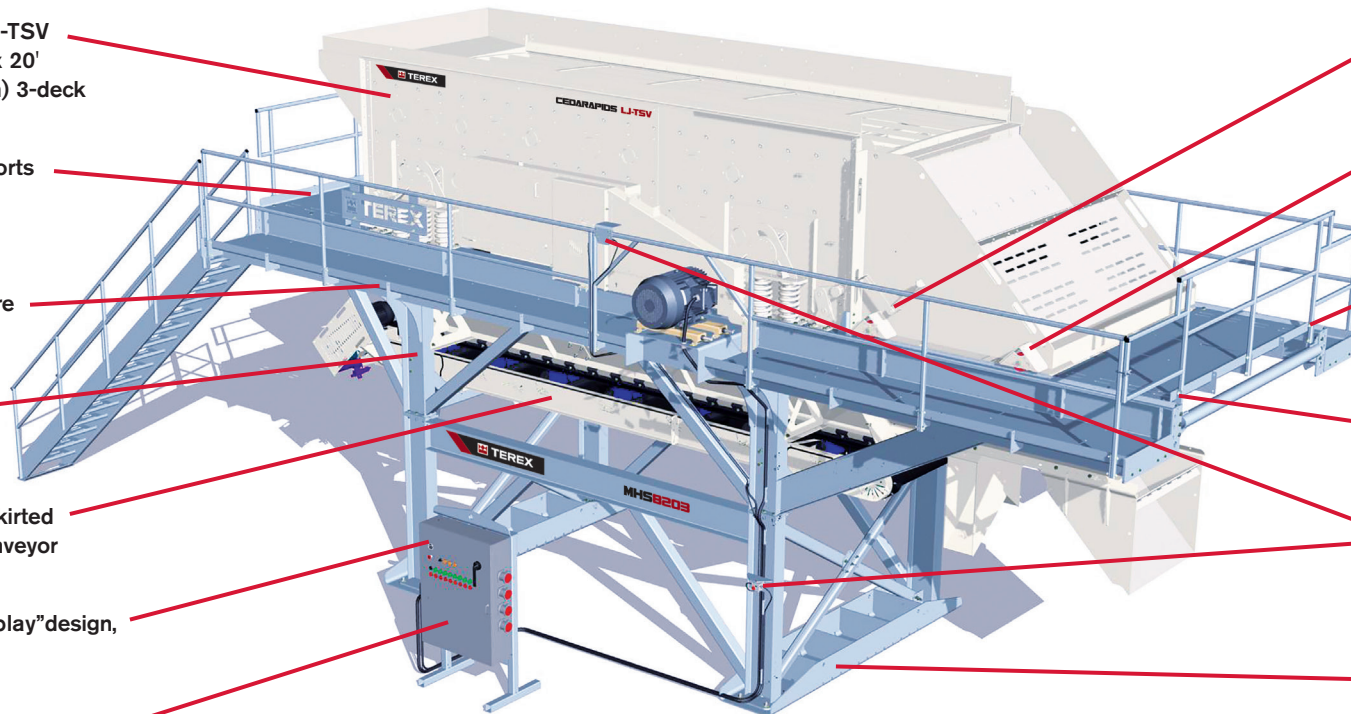

4-section (25%) blending
gate system for all decks

Integrated rolling chute
mechanism and integrated
trouser leg chutes

Galvanized steel structure
including walkways, stairs
and guard rails

Bolts together on site, quick
setup time with basic tools

E-stops located for easy
access on both upper
deck and ground

Optional skid mounting feet
for easy setup at sites without
concrete pads (full-length
skid bases also available)

www.terexmps.com

Effective Date: October 2014. Product specifications and prices are subject to change without notice or obligation. The photographs and/or drawings in this document are for illustrative purposes only. Refer to the appropriate Operator's Manual for instructions on the proper use of this equipment. Failure to follow the appropriate Operator's Manual when using our equipment or to otherwise act irresponsibly may result in serious injury or death. The only warranty applicable to our equipment is the standard written warranty applicable to the particular product and sale and Terex makes no other warranty, express or implied. Terex, the Terex Crown design, Works For You, and Cedarapids are trademarks of Terex Corporation or its subsidiaries. © 2014 Terex Minerals Processing Systems. All rights are reserved.